



TOYOTA A340 SERIES TRANSMISSIONS

2000 & LATER CHECKBALL LOCATIONS

Check ball locations on 2000 and later vehicles using the A340E, F or H series of transmissions is at best, one of the most difficult issues in the transmission industry today. The main reason for this is the checkball locations vary between vehicle models, model years, engine size, and whether it is 2WD or 4WD, this one being the most difficult.

Because of constant demand for this information, we at ATSG are going expand upon this information with one condition, if in using this material, you find a variation that is not illustrated here, we hope you will let us know as soon as possible so that we may keep this information as accurate as possible for the good of the industry.

Refer to Figure 1 for Valve Body Identification for Upper Valve Body, Casting # 8938 Without TV Cable.

Refer to Figure 2 for Checkball Locations for Upper Valve Body, Casting # 8938 Without TV Cable.

Refer to Figure 3 for Small Parts Locations for Lower Valve Body, Casting # 8938 Without TV Cable.

Refer to Figure 4 for Valve Body Identification for Upper Valve Body, Casting # 8934 Without TV Cable.

Refer to Figure 5 for Checkball Locations for Upper Valve Body, Casting # 8934 Without TV Cable.

Refer to Figure 6 for Small Parts Locations for Lower Valve Body, Casting # 8934 Without TV Cable.

Refer to Figure 7 for Valve Body Identification for Upper Valve Body, Casting # 8935 Without TV Cable.

Refer to Figure 8 for Checkball Locations for Upper Valve Body, Casting # 8935 Without TV Cable.

Refer to Figure 9 for Small Parts Locations for Lower Valve Body, Casting # 8935 Without TV Cable

Refer to Figure 10 for Valve Body Identification for Upper Valve Body, Casting # 8938 With TV Cable.

Refer to Figure 11 for Checkball Locations for Upper Valve Body, Casting # 8938 With TV Cable.

Refer to Figure 12 for Small Parts Locations for Lower Valve Body, Casting # 8938 With TV Cable.

UPPER VALVE BODY CASTING NUMBER 8938 4 SOLENOIDS, 1 ACCUMULATOR, NO TV CABLE

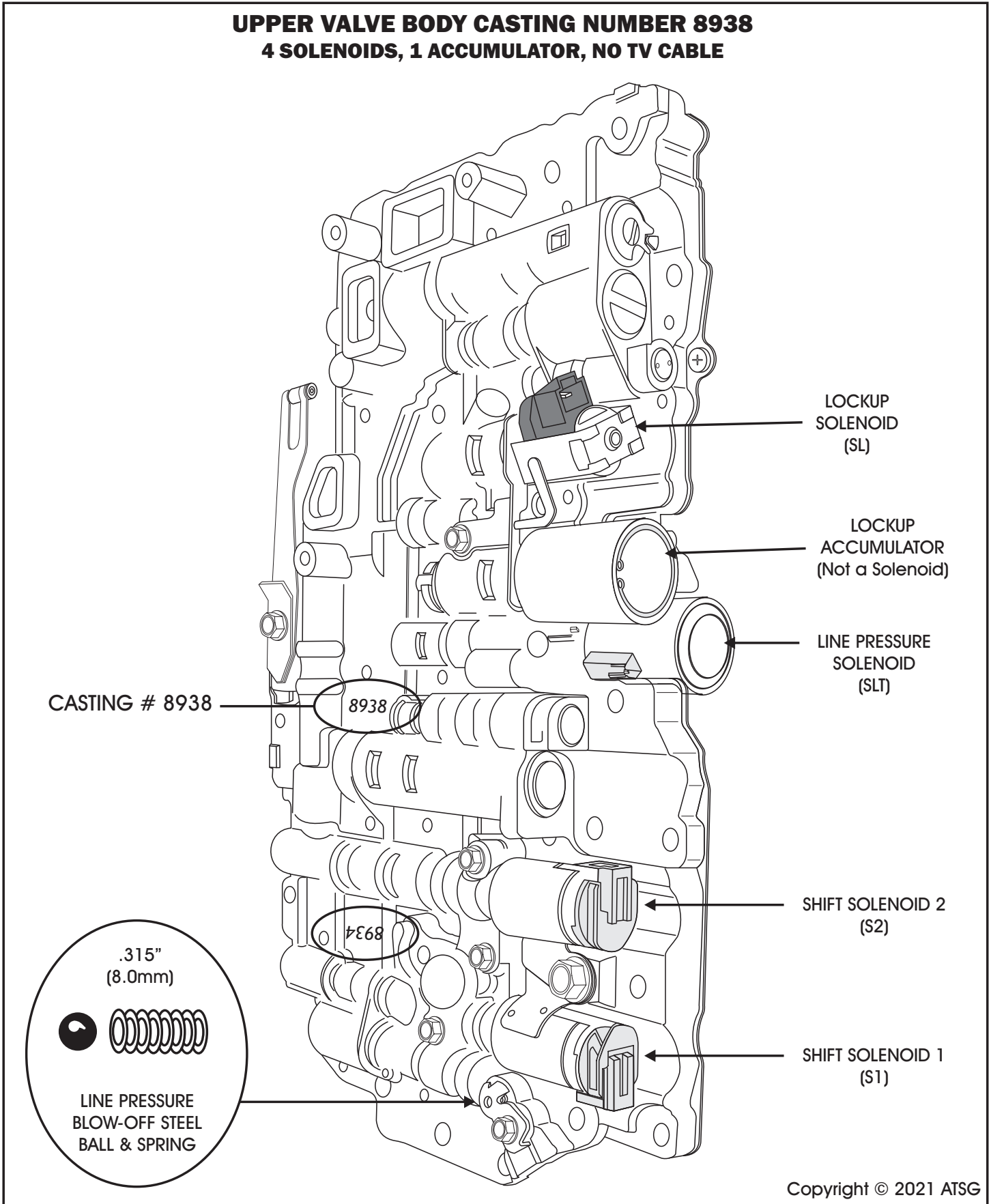

Copyright © 2021 ATSG

Figure 1

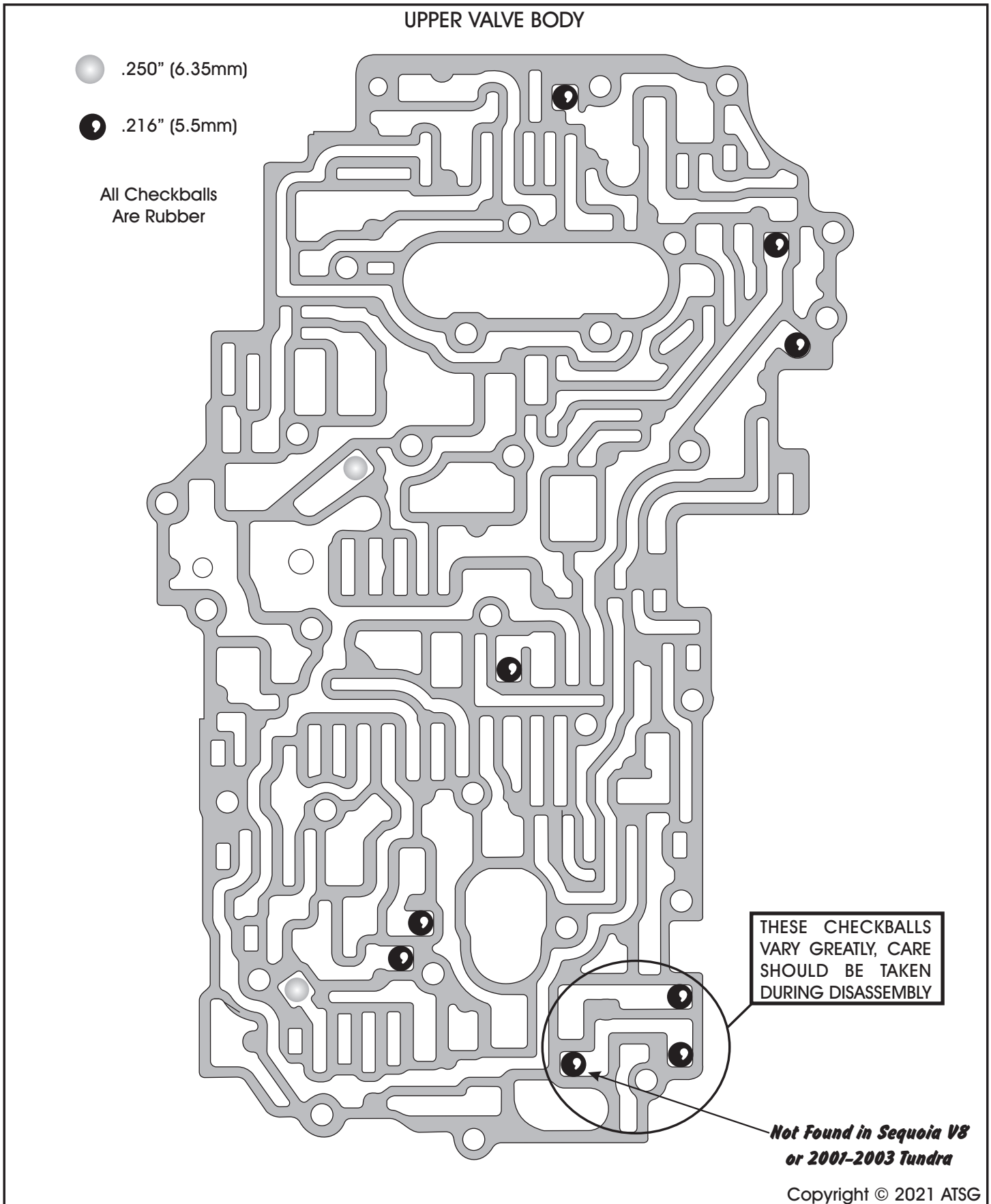

Figure 2

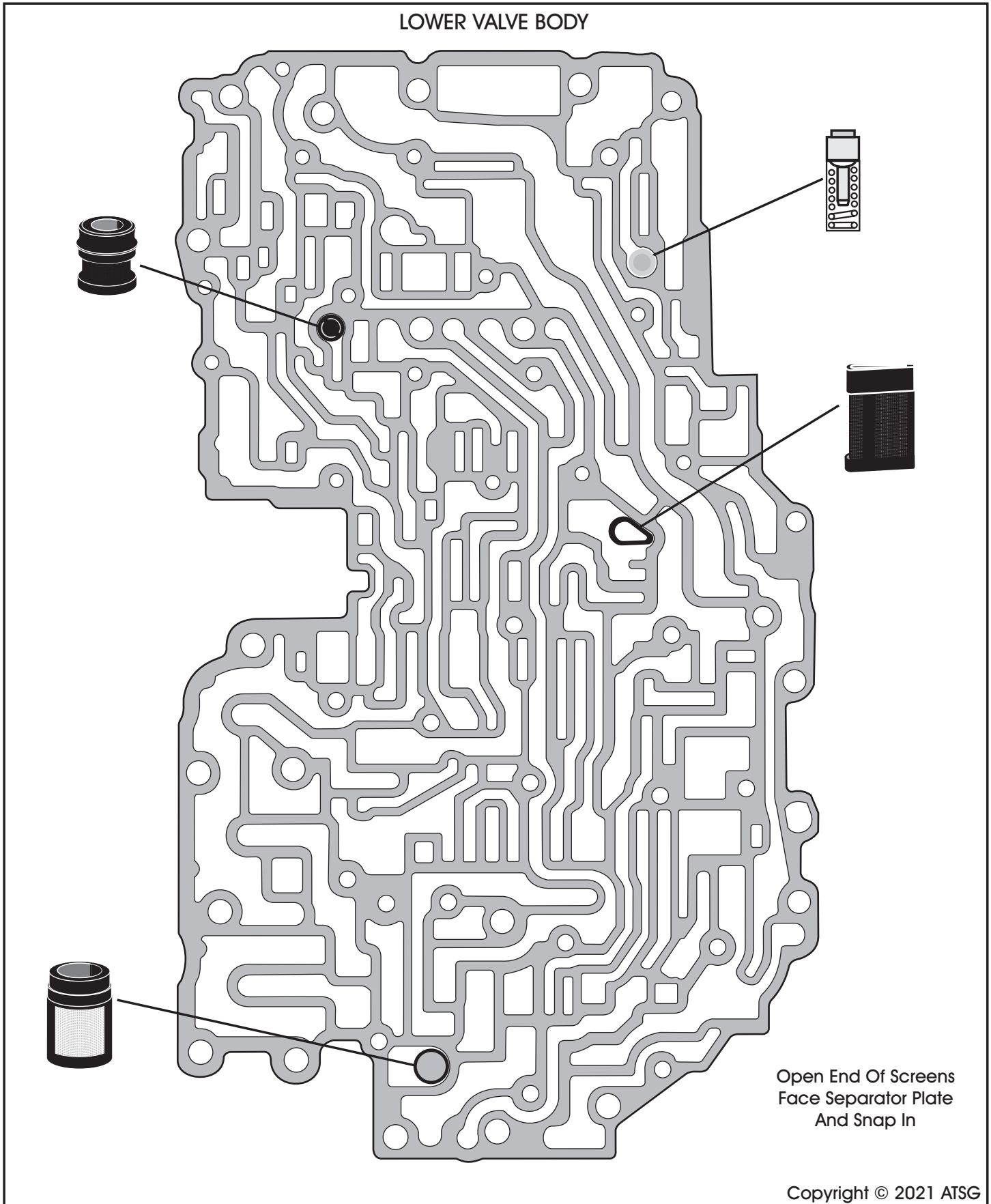

Figure 3

UPPER VALVE BODY CASTING NUMBER 8934 5 SOLENOIDS, LINE PRESSURE BLOW-OFF BALL, NO TV CABLE

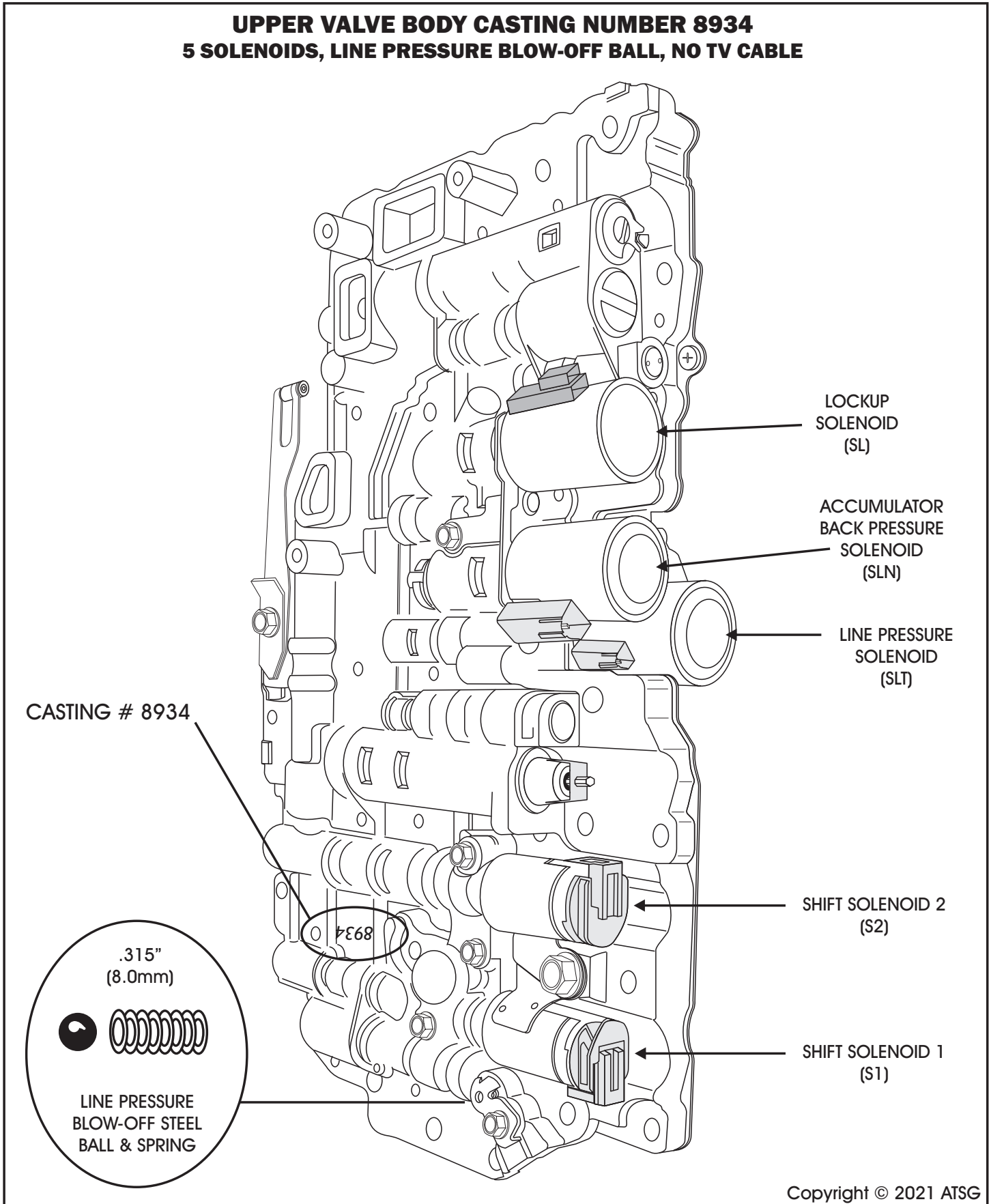

Figure 4

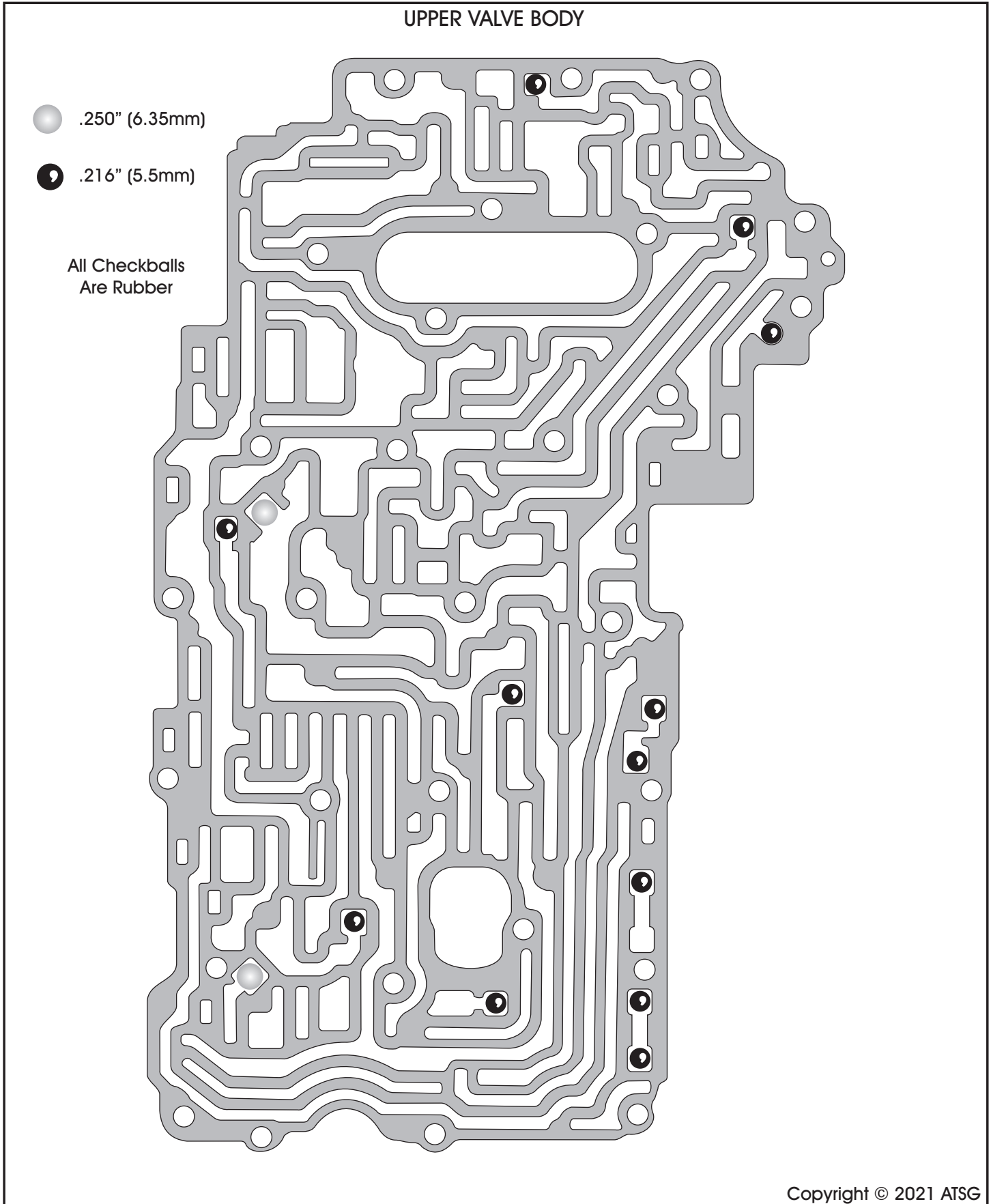

Figure 5

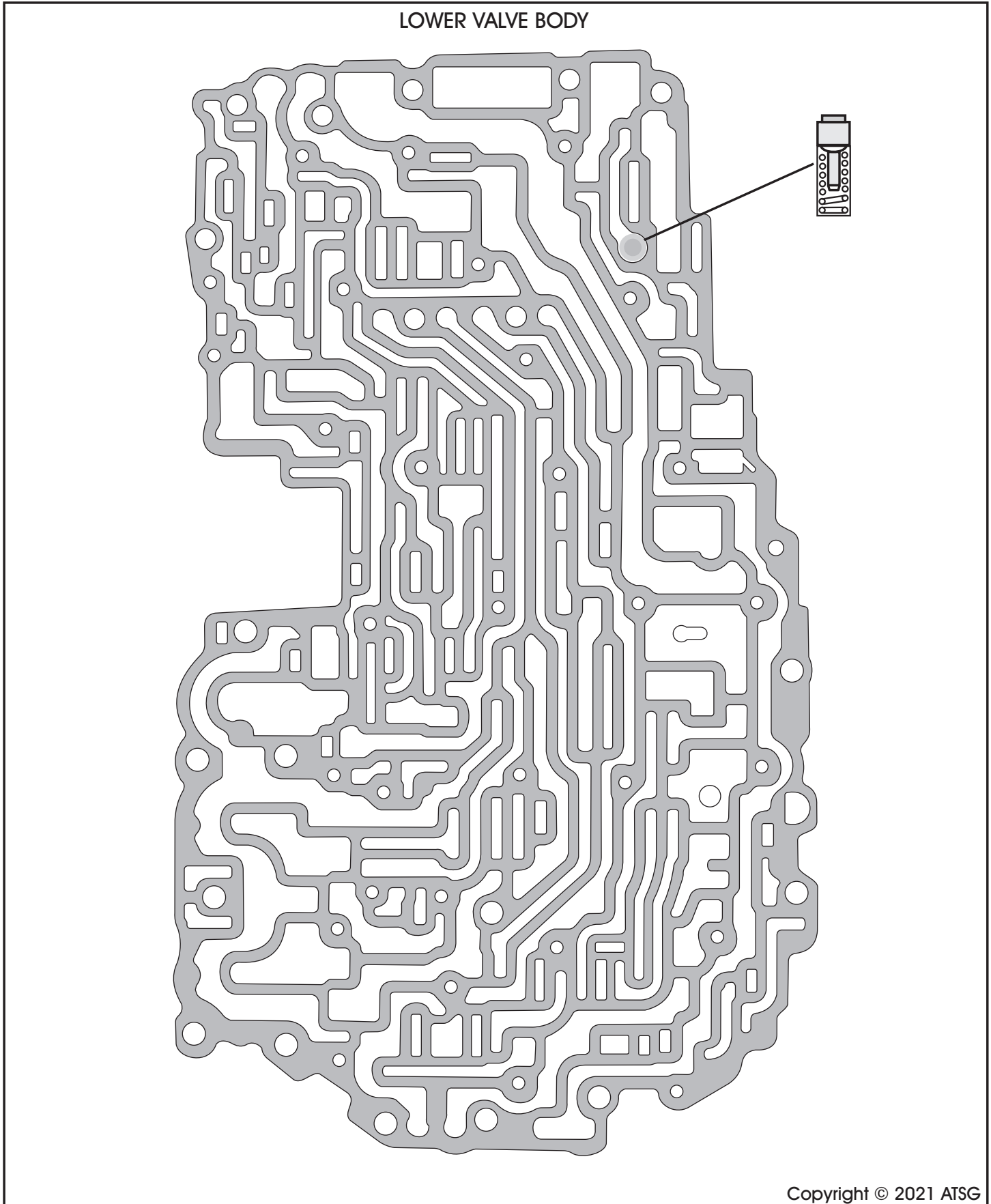
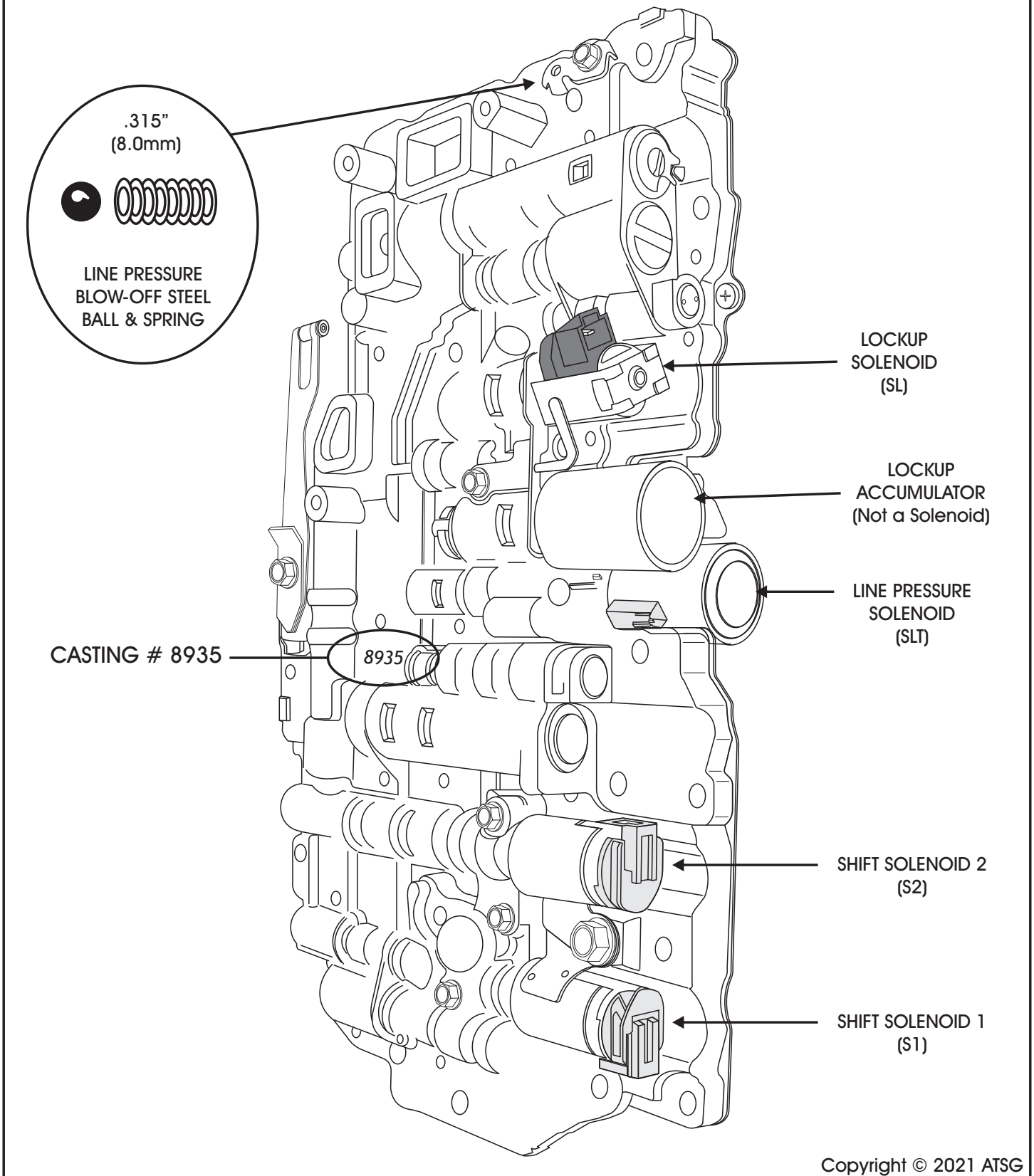

Figure 6

UPPER VALVE BODY CASTING NUMBER 8935

4 SOLENOIDS, 1 ACCUMULATOR, LINE PRESSURE BLOW-OFF BALL, NO TV CABLE



Copyright © 2021 ATSG

Figure 7

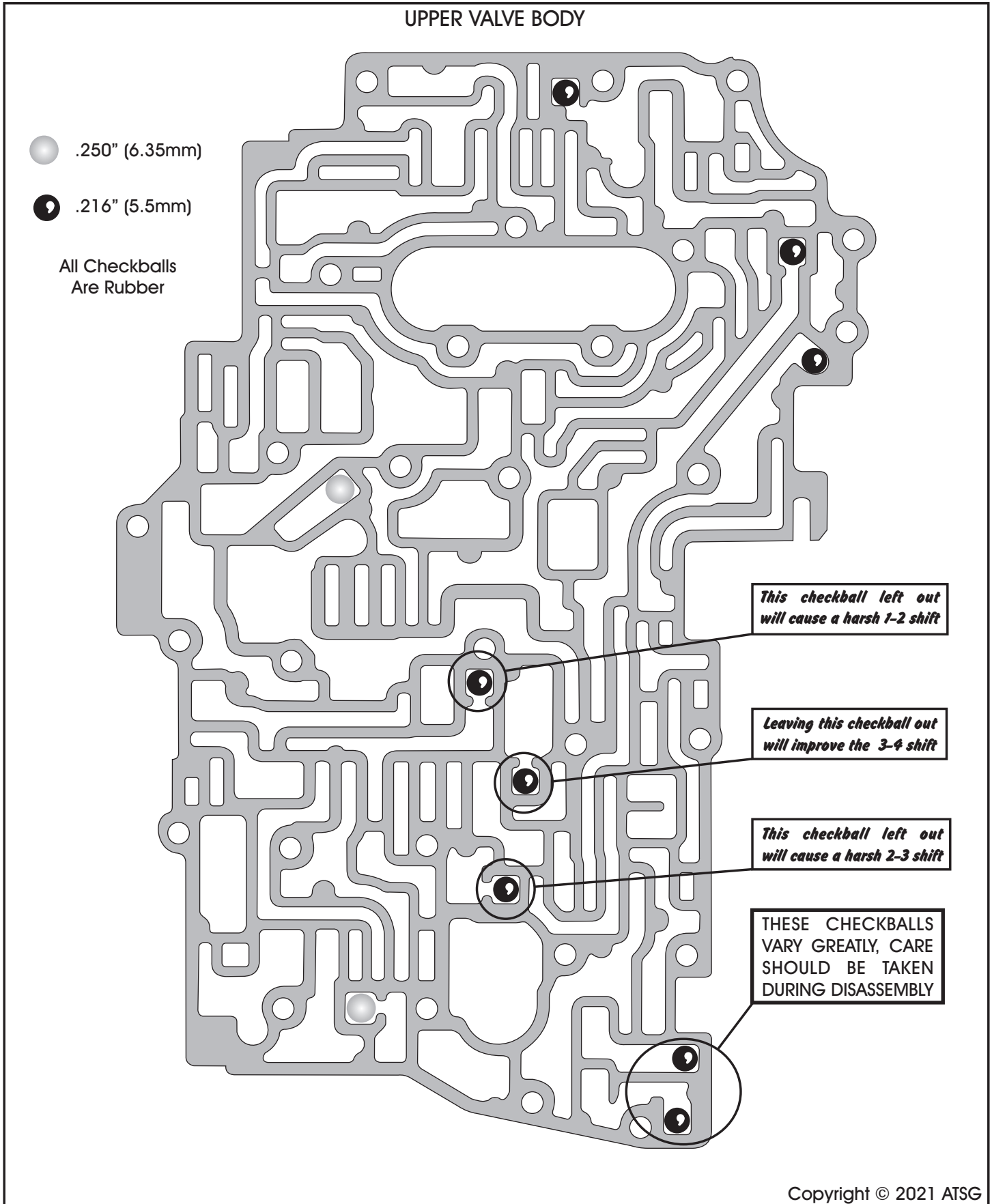

Figure 8

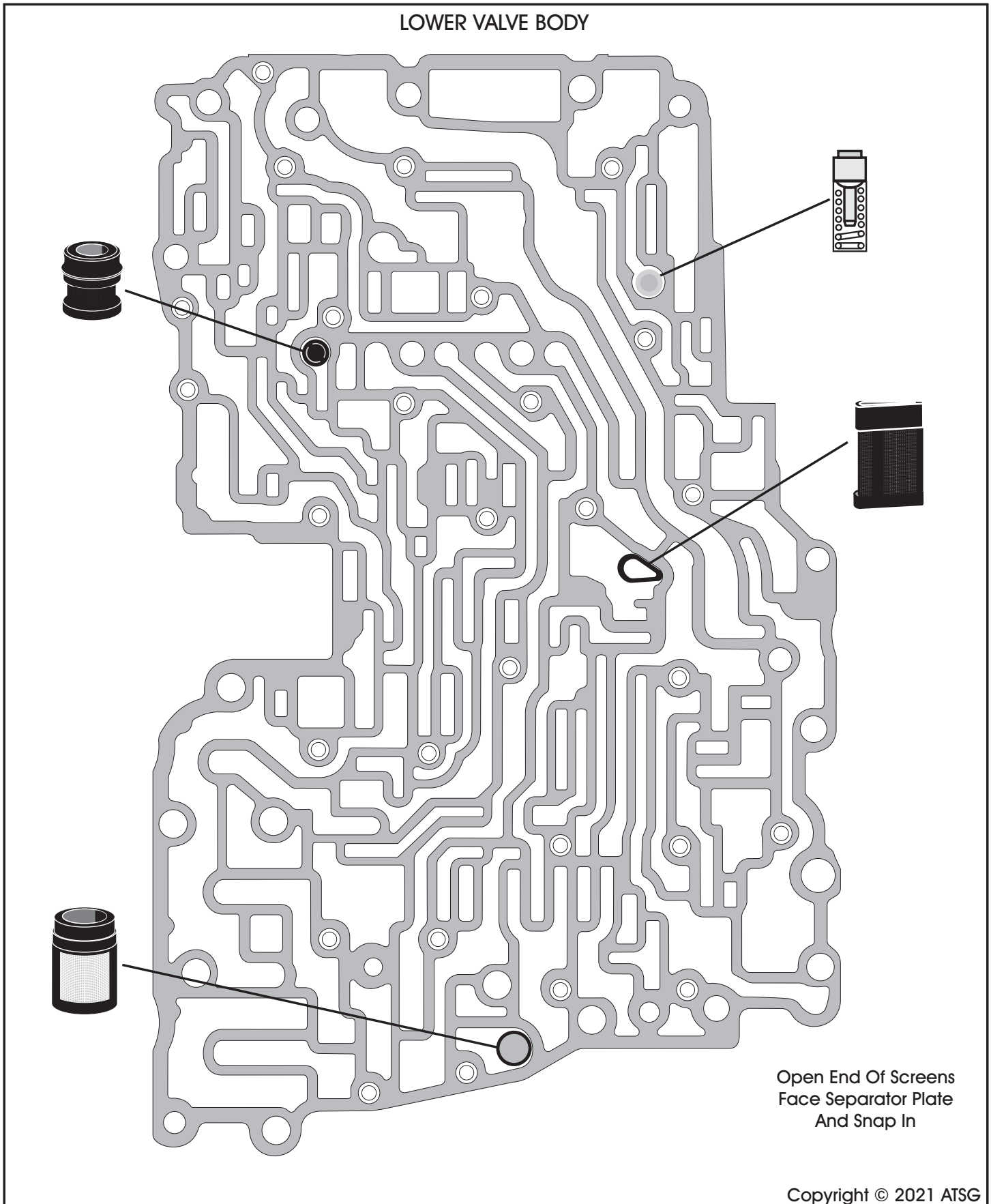
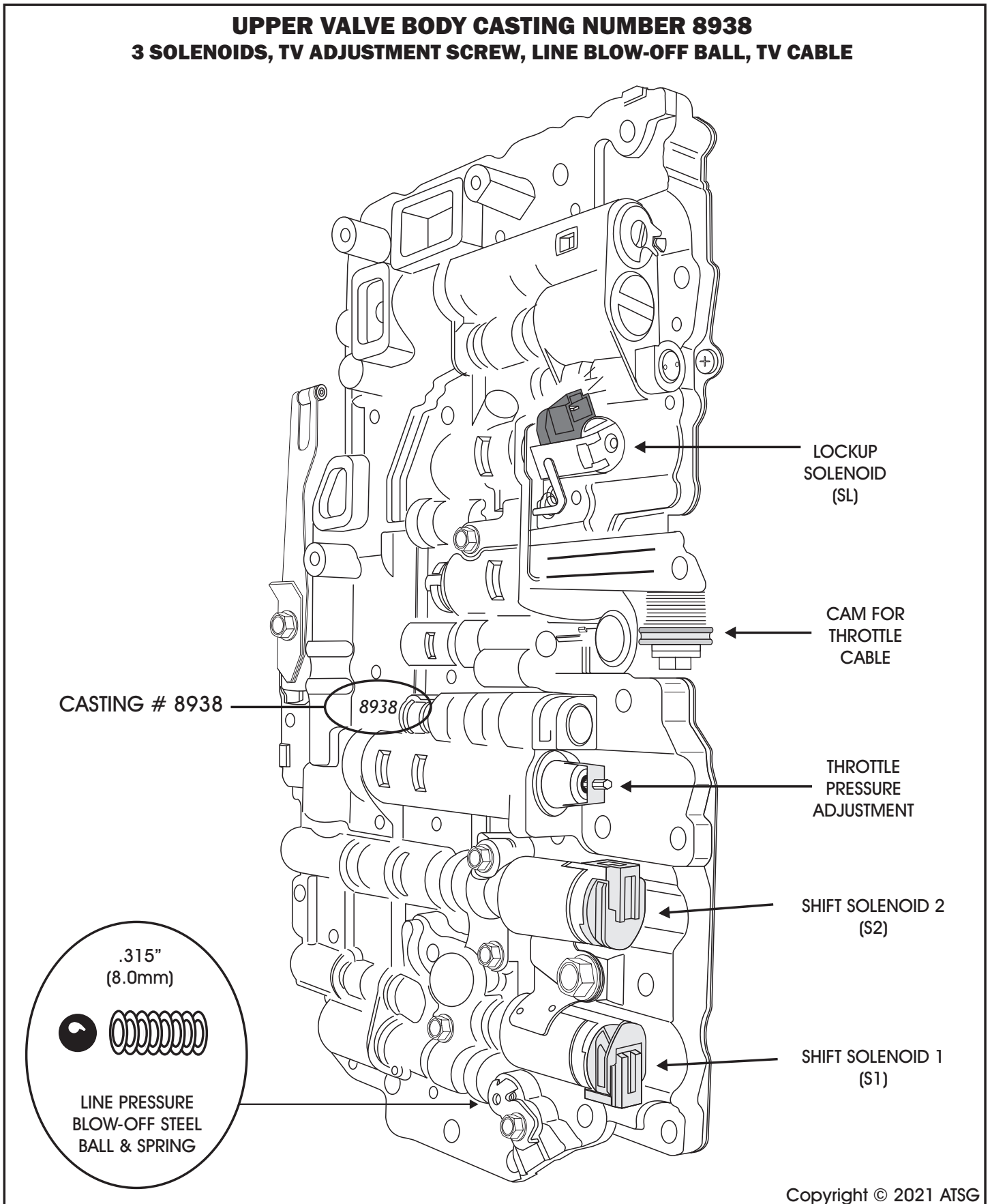

Figure 9

UPPER VALVE BODY CASTING NUMBER 8938 3 SOLENOIDS, TV ADJUSTMENT SCREW, LINE BLOW-OFF BALL, TV CABLE



Copyright © 2021 ATSG

Figure 10

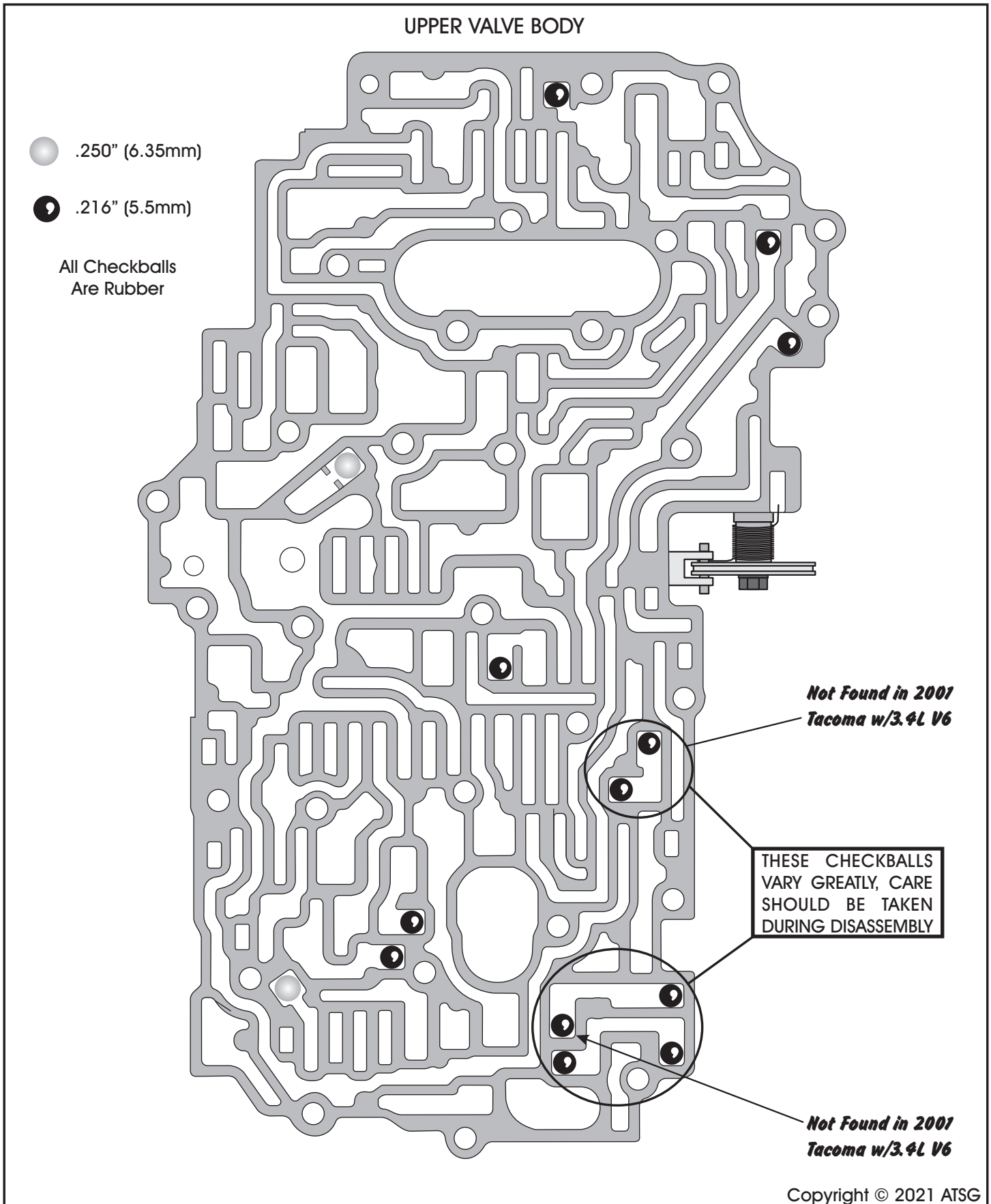

Figure 11

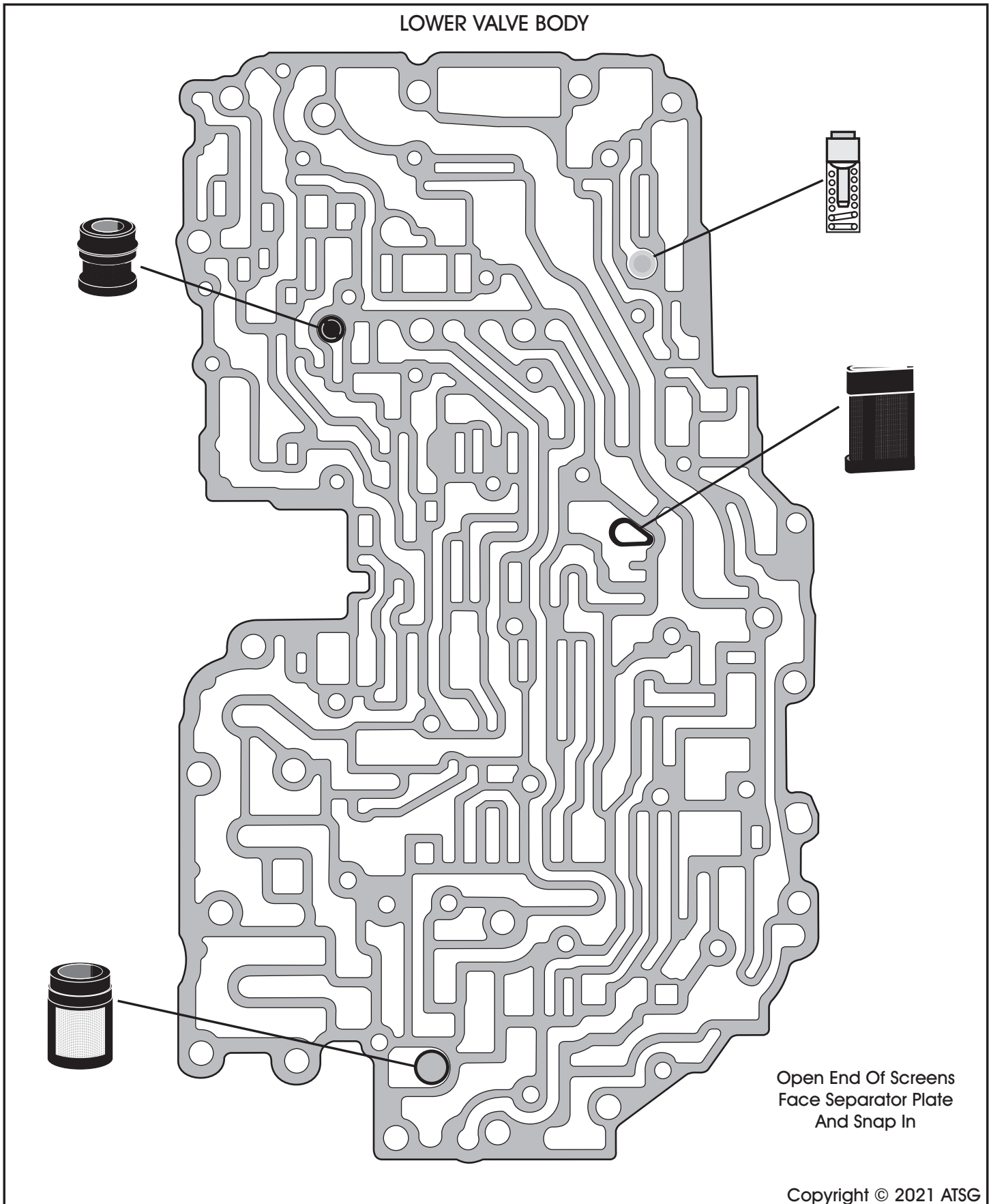

Figure 12